

"SERVING YOU SINCE 1921"



ANTI-SLIP SAFETY STAIR AND WALKWAY PRODUCTS BY "WOOSTER"

CATALOG 94



MAKE EVERY STEP A SAFE ONE!



New Construction

Pages 3 - 13

Existing Buildings

Pages 15-19

WOOSTER PRODUCTS INC

1000 Spruce Street, P.O. Box 6005, Wooster, Ohio 44691
Phone: (330) 264-2844 • Toll Free Phone: 1-800-321-4936 • Fax: (330) 262-4151

FOR QUICK PRICE QUOTATION, DESIGN RECOMMENDATION, ANSWERS TO YOUR QUESTIONS OR LOCAL REPRESENTATION: PHONE TOLL FREE 1-800-321-4936

sales@wooster-products.com • www.wooster-products.com

pg. 9

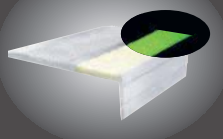

NITEGLOW®

pg. 9

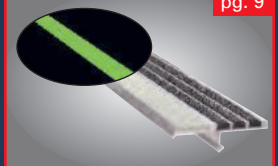

NITEGLOW®

pg. 12

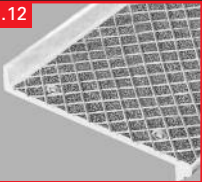

ALUMOGRIT®

pg. 11



ALUMOGRIT® FERROGRIT®

pg. 7

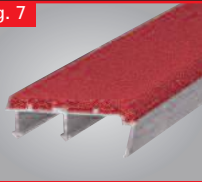

SPECTRA®

pg. 4

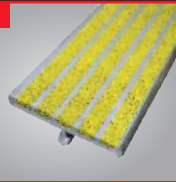

SUPERGRIT®

pg. 15

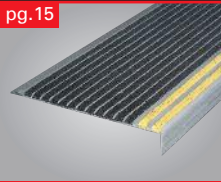

STAIRMASTER®

pg. 17



FLEX-TRED®



WOOSTER PRODUCTS, INC.

1000 Spruce Street, P.O. Box 6005, Wooster, Ohio 44691

330-264-2844 • 800-321-4936 • Fax 330-262-4151

sales@wooster-products.com • www.wooster-products.com



INDEX

Anti-Slip Surface Coverings

Epoxy WP-70	19
Safe-Stride® Paint	19
Walk-A-Sured Epoxy	19
Flex-Tred® Anti-Slip Tape	17-18

Curb Bar

Available Fasteners

Installation Details

Installation Tips

NITEGLOW®

Platforms, Floor Plates

Protective Tape

Existing Buildings

Specifications

Cast	10
Flexmaster®	16
Spectra®	6
Supergrit®	3

Stair Treads, Nosings

Cast	11
For OSHA Barrier-free	4-9
Spectra®	6-7
Supergrit®	3-5

Structural Treads

Cast	12
------	----

Thresholds



INDEX BY TYPE NUMBER

ABRASIVE CAST

Type	Page	Type	Page
100	11	112	13
101	11	113	13
101-SP	11	114	13
102	11	115	13
103	11	115-M	13
104	12	115-S	13
105	12	116	11
105-A	12	116-A	11
106	12	117	12
106-A	12	117-A	12
107	12	119	13
107-A	12	120	11
109	13	150	11
110T	13	250	11
111	13	950	11

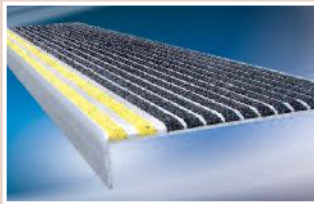

EXTRUDED ALUMINUM

Type	Page	Type	Page
121BF	4	500	15
M231BF-NG	9	500NG	9
WP-1A	7	511, 511SN	15
WP-2	7	540	15
WP-2-NG	9	570	15
WP-2JT	7	610	5
WP-2JT-NG	9	630	15
WP-2C	7	630A	5
WP-2C-NG	9	660	15
WP-2J	7	6100	15
WP-2J-NG	9		
WP-2T	7		
WP-2T-NG	9		
WP-2003	6		
WP-3J	7		
WP-3	7		
WP-3C	7		
WP-3JT	7		
WP-3T	7		
WP-3SP	7		
WP-4J	7		
WP-4C	7		
WP-4T	7		
WP-24	7		
WP-24-NG	9		
WP-24A	7		
WP-24A-NG	9		
WP-RN2SG	5		
WP-RN3SG	5		
WP-RN2SP	6		
WP-RN3SP	6		
WP-RN2-NG	9		
WP-RN3SG-NG	9		
WP-RN3SP-NG	9		
XT3-NG	9		

Wooster Products

ANTI-SLIP SAFETY STAIR and WALKWAY PRODUCTS

Why specify Safety Stair and Walkway Products?

- **'Wooster' Safety Treads and Safety Surfaces** provide anti-slip protection for building occupants and pedestrians.
- The use of **Safety Stair and Walkway Products** can help protect the Building Owner, and pedestrians with the latest available technology for making stairs and walkways safe.
- **'Wooster' Safety Treads and Safety Surfaces** comply with OSHA and other Safety Surface Specifications for anti-slip safety surfaces.

Why specify 'Wooster'?

- A **'Wooster'** specification exemplifies the finest in quality, dependability and service.
- We are **Safety Stair and Walkway** experts! Wooster Products Inc has been furnishing "state-of-the-art" **anti-slip Safety Treads and Safety Surfaces** continuously since 1921!
- Because we provide long-term solutions for your anti-skid needs.

Wooster Products

WAREHOUSE STOCK

- Add extra time for protective tape.
- Many nosings available from stock, extruded or cast. Check with customer service on specific nosings.



Registered U.S. Patent Office



SUPERGRIT® Safety Treads

Specify Supergrit® For:

- Heavy Pedestrian Traffic
- Indoor, Outdoor Installation
- Excellent Safety Protection at Low Cost

- New Construction or Existing Stairs
- Non-combustible

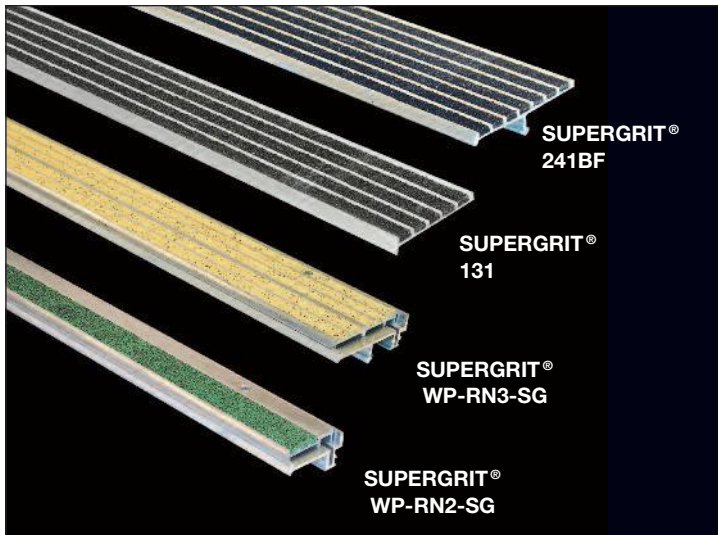

SUPERGRIT® TYPE 131

Supergrit® Treads Provide...

A heat-treated, corrosion resistant, extruded aluminum base with satin/lacquered finish. The use of diamond-hard aluminum oxide in the filler assures long tread life under heavy pedestrian traffic. Supergrit® is designed for both inside and outside use.

Supergrit® Features:

- Extruded aluminum base – abrasive filler
- Lengths to order, up to 12'0" (3.66 m) in one piece
- Lengths over maximum to be made in equal sections
- Non-combustible
- High content of aluminum oxide abrasive
- 11 standard colors
- Colors extend throughout filler
- Protective tape available at extra cost



SAFETY TREADS IN COLORS

Time-proven Supergrit® safety treads are available in colors for improved aesthetics.

SUPERGRIT®/STAIRMASTER® COLORS

Standard color is black. Black will be shipped unless another color is specified. See color chart below for other colors available.



Actual tread color may vary slightly from printed sheet. Request tread sample if color is critical.

SUPERGRIT® SPECIFICATION:

Provide Supergrit® type _____ safety nosings as manufactured by Wooster Products Inc. for interior and exterior stairs.

- Nosing base to be type 6063-T5 extruded aluminum.
- Anti-slip filler shall contain approximately 65% virgin grain Aluminum Oxide (AL₂O₃) abrasive.
- Nosings shall be non-combustible as tested under Federal Test Method Standard No. 501a, Method 6411.
- Type of anchor shall be as specified. See page 14 for anchor details.
- Nosings shall terminate not more than 4" (101.6 mm) from ends of steps for poured concrete stairs; for concrete-filled steel pan stairs, nosings shall be full length of steps less 1/8" (3.05 mm) clearance.
- Color shall extend uniformly throughout the filler; black color will be furnished if no other color is specified.
- Protective tape available upon request, at an extra cost.
- Protective tape should be removed as soon as possible once installed.

Note: Safety nosings going into new poured concrete or cement fill shall be installed before "INITIAL SET" of the concrete or cement occurs.

Nosings shall finish flush with the top of the traffic surface.

NEW CONSTRUCTION

Please call Wooster Products Inc for current availability.

SUPERGRIT® PROFILES FOR NEW CONCRETE STAIRS AND FOR STEEL PAN

MAXIMUM PIECE LENGTH IS 12 FEET

THE DUAL PURPOSE STAIR NOSING BY 'WOOSTER'

STEEL PAN: Concrete filled, installed stringer to stringer less 1/8" clearance.

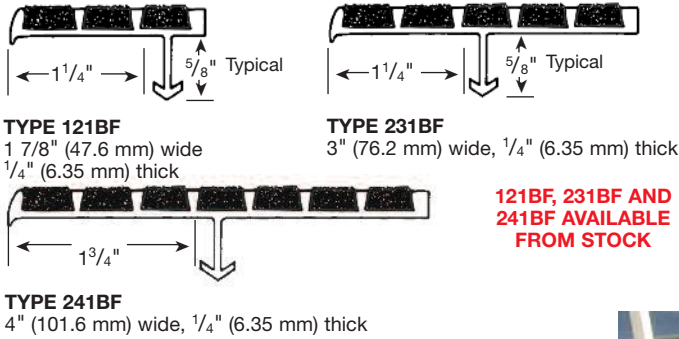

121BF, 231BF AND 241BF AVAILABLE FROM STOCK

THESE SECTIONS AVAILABLE WITH COUNTERSUNK HOLES AND FASTENERS

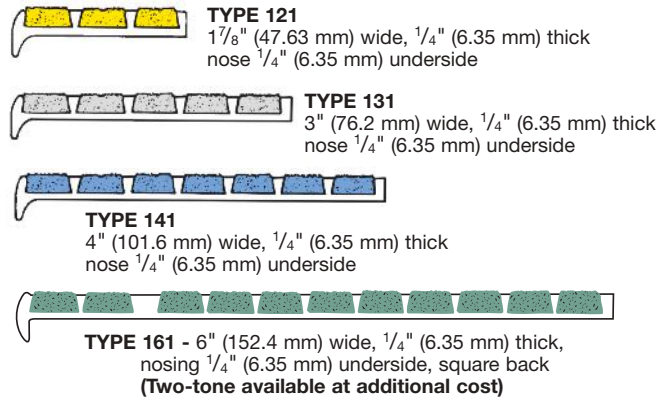

DETAIL

Sure-hold anchor in concrete step.

Designed to install so that there is no projection past the face of the riser.

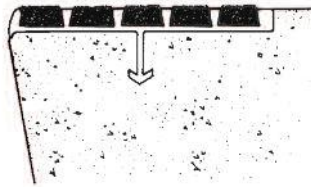

DETAIL

Sure-hold anchor in sloped riser steel pan step.

NOTE: Nose design provides better fit at formed edge of steel pan.

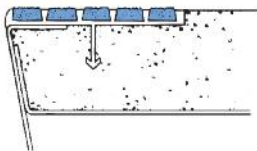

SUPERGRIT® PROFILES FOR STEEL PAN CONCRETE-FILLED STAIRS

MAXIMUM PIECE LENGTH IS 12 FEET

Full stringer length, less 1/8" clearance.

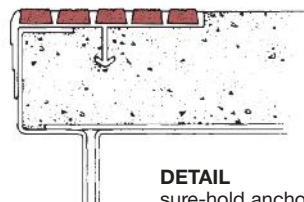
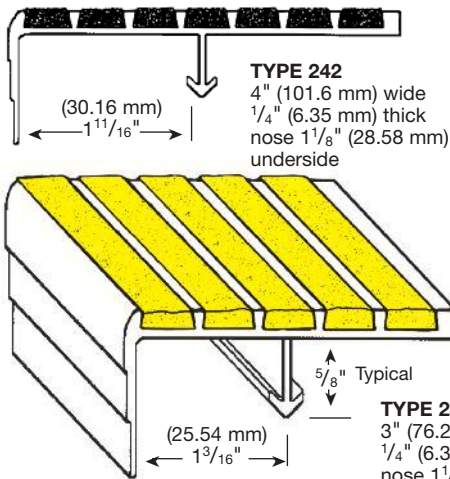

SECTIONS NOT TO SCALE

THESE SECTIONS AVAILABLE WITH COUNTERSUNK HOLES AND FASTENERS

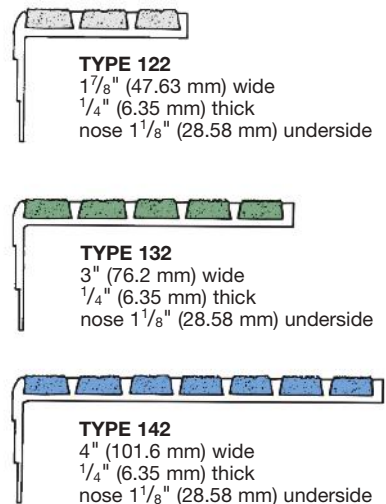

SUPERGRIT® 2-STAGE STAIR NOSING FOR STEEL PAN OR POURED CONCRETE STEPS

MAXIMUM PIECE LENGTH IS 8 FEET

Specify SUPERGRIT® Replaceable Stair Nosings For:

- Fast easy replacement if damaged
- Visual appearance and durability
- Secure anchorage
- Indoor or outdoor use
- Matching or contrasting color decor
- Non combustible
- Heavy pedestrian traffic
- Premium quality construction with no clatter and an architecturally clean design.
- Nosings can be furnished with disposable wood insert for use during construction phase. After construction nosing inserts are installed for fresh, clean appearance.
- Furnished with SUPERGRIT® Filler in a wide range of colors.
- Steel pan or poured concrete steps.

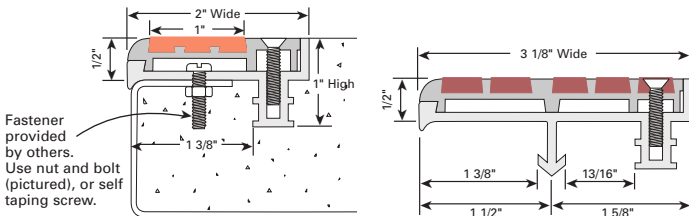
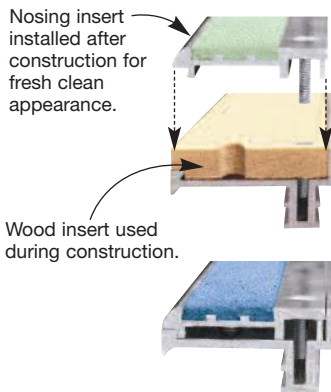

TYPE WP-RN2SG
2" (50.8 mm) wide,
1/2" (12.7 mm) thick

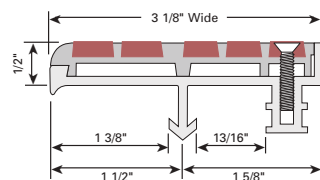

TYPE WP-RN3SG
3 1/8" (79.375 mm) wide
1/2" (12.7 mm) thick

NAVSEA LADDER TREADS

Sizes 4" – 6" – 9" • MIL-T-24634 (SH)
Custom Lengths • Full Treads • Cap Treads

TYPE I FULL TREAD

- 4" - Model 841
- 6" - Model 861
- 9" - Model 891



TYPE II CAP TREAD

- 4" - Model 842
- 6" - Model 862
- 9" - Model 892



* National Safety Council information

FOR POURED CONCRETE OR STEEL PAN STAIRS

MAXIMUM PIECE LENGTH IS 12 FEET

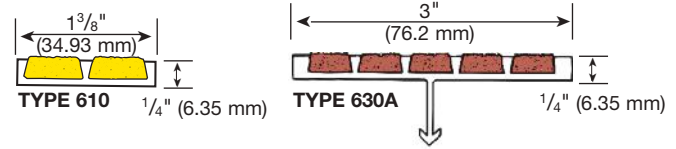

HAS RECESS FOR TILE

TYPE 431

3 1/2" wide (88.9 mm),
1/4" (6.35 mm) thick,
1/4" (6.35 mm) nose underside
Specially designed with recessed
back to receive 1/8" (3.05 mm) tile.

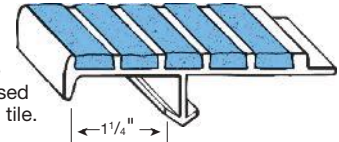

FOR USE WITH SLOPED RISERS

TYPE 238

3" (76.2 mm) wide
1/4" (6.35 mm) thick
1 1/8" (28.58 mm) nose underside

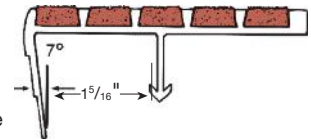

TYPE 138

3" (76.2 mm) wide
1/4" (6.35 mm) thick
1 1/8" (28.58 mm) nose underside
Specially designed for steel
pan stairs with sloped risers

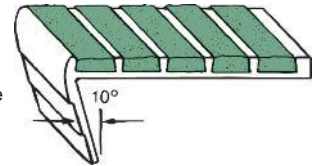

HAS VARIABLE NOSE DEPTH

TYPE 133

3" (76.2 mm) wide
1/4" (6.35 mm) thick
1 3/4" (44.45 mm) nose underside

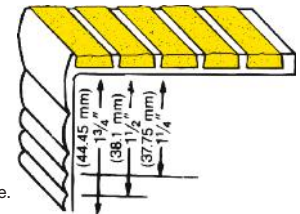

Nose can be sheared for additional charge.

SUPERGRIT® CURVED & MITERED TREADS

FOR MOST RADIUS APPLICATIONS – CONSULT FACTORY

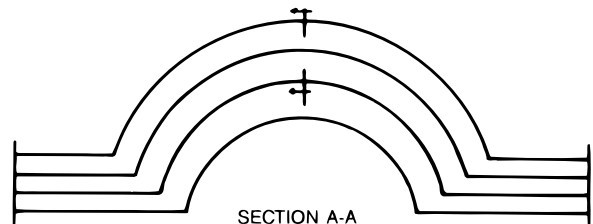

The tread provides non-slip protection as well as protection for the edge of the stair, preventing chipping and wear. Treads are shipped ready for installation.

- Lengths as required to 10' 0" (3.048 m)
- Curves and miters to drawings or template
- Minimum radius 3' 0" (914.4 mm)
- Guaranteed uniformity of width and thickness insures easy backing with floor tile
- Lead times increase for curved treads
- Only the following SUPERGRIT® treads are curved; types 121, 121BF, 131, 141, 231BF, 241BF, 630, 630A, 610

Specify Spectra® For:

- Best Architectural Aesthetics
- Matching or Contrasting Color Decor
- Indoor or Outdoor Use
- Heavy Pedestrian Traffic
- Non-combustible



SPECTRA® NOSING TYPE WP3C

SAFETY TREADS IN COLORS

Designed to enhance the safety and beauty of every architectural installation.

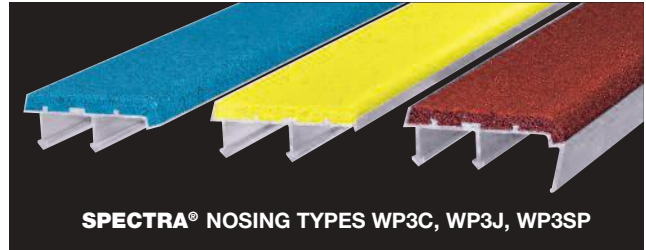

SPECTRA® NOSING TYPES WP3C, WP3J, WP3SP

SPECTRA® SPECIFICATION:

Provide Spectra® type _____ safety nosings as manufactured by Wooster Products Inc for interior and exterior stairs.

- Nosing base to be type 6063-T5 extruded aluminum.
- Anti-slip filler shall contain approximately 60% virgin grain Aluminum Oxide (AL₂O₃) abrasive.
- Binder is to be a fully-cured resilient type epoxy; epoxy binder to filler ratio to be 13% minimum for improved cleanability.
- Epoxy/Abrasive filler shall be securely bonded to the extruded aluminum base.
- Type of anchor shall be as specified. See page 14 for anchor details.
- Nosings shall terminate not more than 4" (101.6 mm) from ends of steps for poured concrete stairs; for concrete-filled steel pan stairs, nosings shall be full length of steps less 1/8" (3.05 mm) clearance.
- Color shall extend uniformly throughout the filler; black color will be furnished if no other color is specified.
- Protective tape available upon request at additional cost.
- Protective tape should be removed as soon as possible once installed.

SPECTRA® TREADS PROVIDE...

A high content of aluminum oxide abrasive grit for long life and lasting beauty. Spectra's safety surface has easy maintenance features and insures excellent protection from liability of falls and injuries.

SPECTRA® FEATURES:

- Extruded aluminum base – abrasive filler
- Lengths to order, up to 10' 0" (3.048 m) in one piece
- Lengths over maximum to be made in equal sections
- Anti-slip abrasive extending over radius of nose
- High content of aluminum oxide abrasive
- 18 standard colors
- "Clean" architectural lines
- Protective tape available at extra cost
- Non-combustible



Note: Safety nosings going into new poured concrete or cement fill shall be installed before "INITIAL SET" of the concrete or cement occurs.

Nosings shall finish flush with the top of the traffic surface.

SPECTRA® TWO STAGE STAIR NOSING WITH REPLACABLE WOOD INSERT FOR PROTECTION DURING CONSTRUCTION
 MAXIMUM PIECE LENGTH IS 8 FEET

- Premium quality construction with no clatter for an architecturally clean design.
- Designed for installation on steel pan stairs or poured concrete steps.
- Nosings can be furnished with disposable wood insert for use during construction phase. After construction anti-slip inserts are installed for a fresh, clean appearance.
- Furnished with Spectra filler in a wide range of colors.
- Nosings can be replaced if damaged, without costly demolition of stairs.
- For steel pan or formed concrete steps.
- Spectra® features Non-combustible per Federal Test 501a

- Fast easy replacement
- Visual appearance and durability
- Secure anchorage
- Indoor or outdoor use
- Matching or contrasting color decor
- Non combustible
- Heavy pedestrian traffic

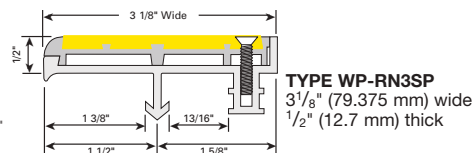
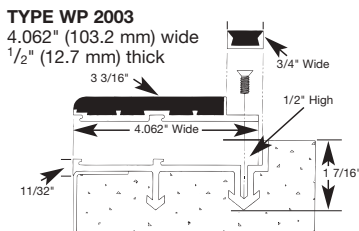
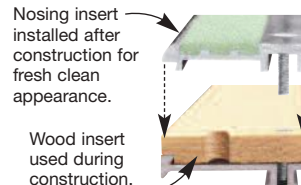
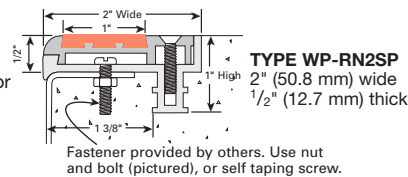

NEW CONSTRUCTION

Specify Spectra® For:

- Best Architectural Aesthetics
- Matching or Contrasting Color Decor
- Indoor or Outdoor Use
- Heavy Pedestrian Traffic
- Non-combustible

Please call Wooster Products Inc for current availability.

SPECTRA® PROFILES FOR NEW CONCRETE STAIRS

MAXIMUM PIECE LENGTH IS 10 FEET

Custom lengths to ± 1/16".

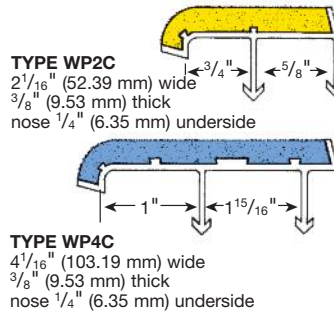
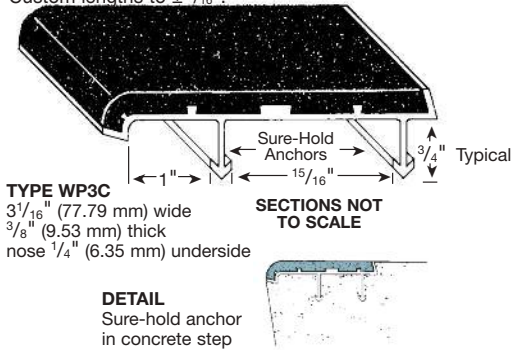

THESE SECTIONS AVAILABLE WITH COUNTERSUNK HOLES AND FASTENERS

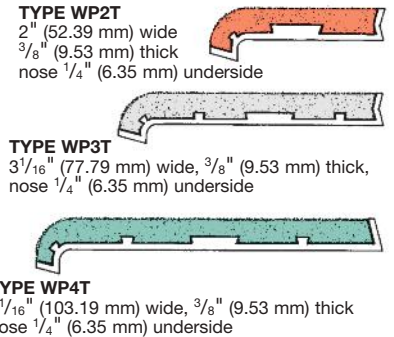

SPECTRA® PROFILES FOR STEEL PAN CONCRETE-FILLED STAIRS

MAXIMUM PIECE LENGTH IS 10 FEET

Generally installed full stringer to stringer length, less 1/8" clearance.

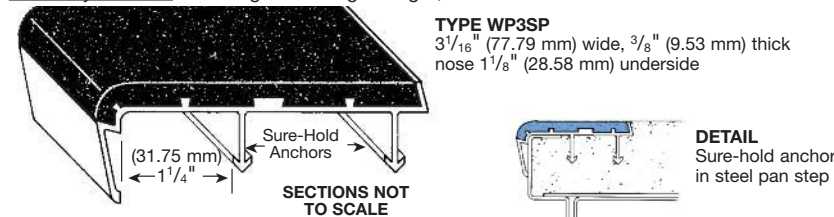

THESE SECTIONS AVAILABLE WITH COUNTERSUNK HOLES AND FASTENERS

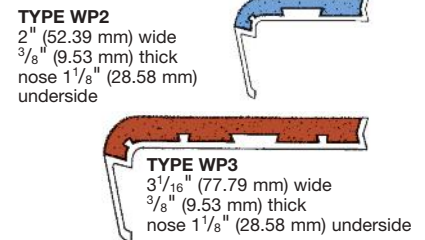

SPECTRA® PROFILES FOR SLOPED RISER STEEL PAN STAIRS...

MEETS OSHA BARRIER-FREE DESIGN, MAXIMUM PIECE LENGTH IS 10 FEET

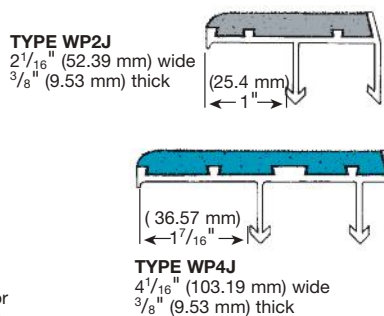
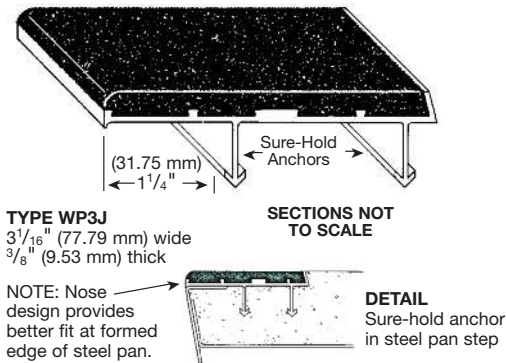

THESE SECTIONS AVAILABLE WITH COUNTERSUNK HOLES AND FASTENERS

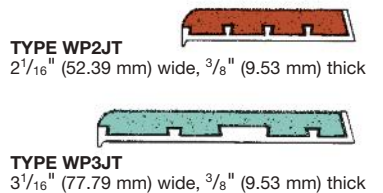

This series is designed to meet the OSHA requirements of the barrier-free code for stair construction.

MAXIMUM PIECE LENGTH IS 10 FEET

SPECTRA® RECESSED INTO STEP SURFACE



SPECTRA® FOR NEW CONCRETE

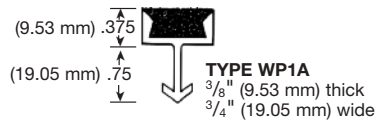

CALIFORNIA TITLE 24 NOSINGS

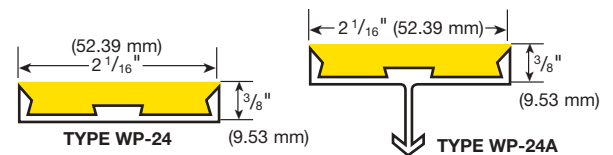

SPECTRA® COLORS

Standard color is black. Black will be shipped unless another color is specified. See color chart below for other colors available. Actual tread color may vary slightly from printed sheet. Request tread sample if color is critical.

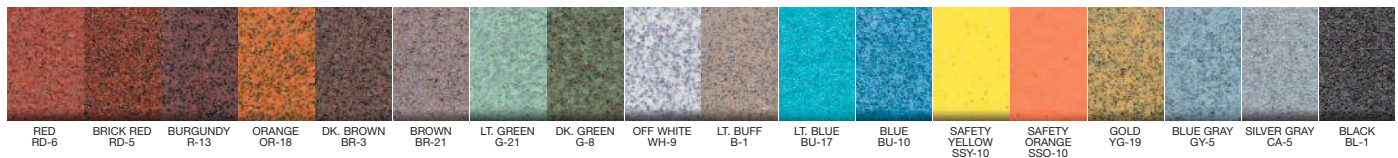



NITEGLOW®

Anti-Slip Glow-in-the-Dark Safety Treads

**IBC and IFC
COMPLIANT!
NYC MEA
APPROVED!**

NITEGLOW®



- **Illuminate dark egress paths**
- **Entire photoluminescent area is slip resistant**
- **Recharged by any light source, natural or artificial**

SAFETY GUIDANCE SYSTEMS

Bring your building into compliance with the NYC, International Building and International Fire Codes. Section 1024 of the IBC and IFC codes call for Photoluminescent markings to be used in egress exit stairwells of buildings over 75 feet tall. As follows:

- **CODE 1024.2.1 STEPS** – continuous stripe on leading edges – utilize models 333-NG or 500-NG
- **CODE 1024.2.2 LANDINGS** – continuous stripe on the leading edge – utilize models 333-NG or 500-NG
- **CODE 1024.2.3 HANDRAILS AND EXTENSIONS** – Stripe on the top of handrails – utilize model 408.3
- **CODE 1024.2.4 PERIMETERS** – solid stripe on landings and other floor areas within exit enclosures. Either wall or floor mounted. Utilize model 408.3
- **CODE 1024.2.5 OBSTACLES** – obstacles projecting more than 4" or below 6'6" shall be marked with alternating bands of luminescent and black strips – utilize model 412.2
- **CODE 1024.2.6 DOORS FROM EXIT ENCLOSURES** – marked with a luminous exit symbol – utilize models 40.10 - 40.13 or 40.22 (consult factory for additional signs)
- **CODE 1024.2.6.2 DOOR HARDWARE** – shall be marked with no less than 16 square inches of luminous material – utilize models 40.21 or 408.3
- **CODE 1024.2.6.3 DOOR FRAME** – Top and sides of doors shall be marked with continuous luminous stripes – utilize models 408.3

• **TREADS AND NOSINGS ARE NYC MEA APPROVED** •

• **NOSING AND TREADS AVAILABLE TO MEET 2009 INTERNATIONAL BUILDING CODE** •

• **PRODUCTS COMPLY WITH 2009 INTERNATIONAL FIRE CODE, NFPA 101 AND 5000 AND GSA** •

**SAFETY TREAD OF
CHOICE ON ALL FOUR
NYC WORLD TRADE
CENTER TOWERS!**

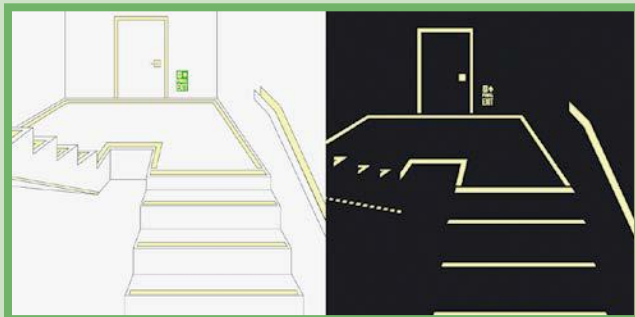

NITEGLOW® EPOXY COATING AND PRIMER

NITEGLOW® Epoxy Coating NG-100
NITEGLOW® Primer 114 MEA approved

- The two-part single coat epoxy glow-in-the-dark system is a thick coating that is applied with a putty knife. The kit comes with fast drying (30-60 minutes) ultra white reflective acrylic primer used to enhance the glow. Comes in quart can kits which include: fast drying white primer, glow epoxy and hardener, putty knife, and mixing arm. NITEGLOW® epoxy coatings NG-100 and NG-200 can be applied to almost any surface.



GUIDELINES FOR STEPS & LANDINGS PHOTOLUMINESCENT (GLOW-IN-THE-DARK) REQUIREMENTS.

- The entire horizontal leading edge of each step and landing shall be marked with a solid and continuous stripe of photoluminescent material. The dimensions, distances and locations shall be uniform throughout.

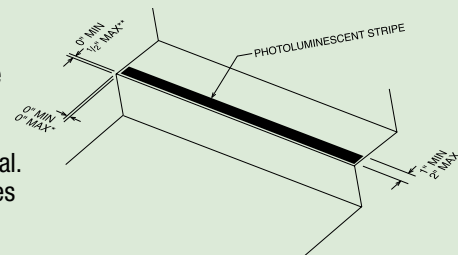

FEATURES

Our pigment is *embedded* in a hard epoxy mixture, it is *not* just a thin adhesive tape or coating.



Glow in the dark treads are not designed to provide enough light to illuminate the dark egress path, but rather to provide luminescent outlines of the egress stairs.

NEW CONSTRUCTION

New York City Products have been Tested and Approved for: Brightness rating: ISO 17398:2004;

Washability: ASTM D 4828-1994 (2303); Toxicity Bombardier: SMP 800-C; Radioactivity: ASTM D 3648-2004; Flame Spread: ASTM D 635-2003

800-321-4936 www.wooster-products.com



NITEGLOW®

Anti-Slip Glow-in-the-Dark Safety Treads

Maximum piece length of all Niteglow® stair treads and nosings is 8 feet

IBC and IFC COMPLIANT!
NYC MEA APPROVED!

COMPLETE SYSTEM TO BRING YOUR BUILDING UP TO IBC, IFC, AND NYC CODE COMPLIANCE.

NITEGLOW® PHOTOLUMINESCENT STAIR NOSINGS & TREADS

MOST POPULAR

M231BF-NG

3" wide

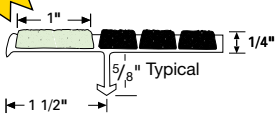

WP2J-NG

2 1/8" wide

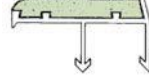

WP2JT-NG

2 1/8" wide

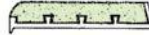

With Anchor: WP-24A-NG

NO Anchor: WP-24-NG

2 1/8" wide



WP2-NG

2" wide

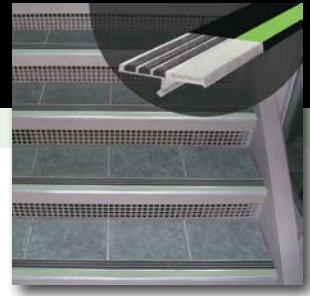

NITEGLOW® TWO STAGE STAIR NOSING WITH REPLACABLE WOOD INSERT FOR PROTECTION DURING CONSTRUCTION

- Fast easy replacement if damaged
- Visual appearance and durability
- Secure anchorage
- Wood insert for construction phase
- Steel pan or poured concrete steps
- Indoor or outdoor use
- Non-combustible
- Heavy pedestrian traffic
- Maximum length 8 feet

WP-RN2-NG

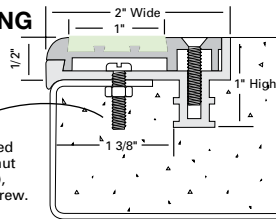

Fastener provided by others. Use nut & bolt (pictured), or self taping screw.

WP-RN3SG-NG

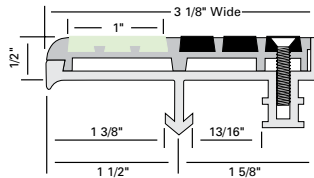

WP-RN3SP-NG

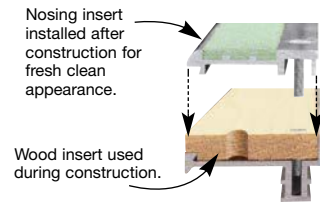
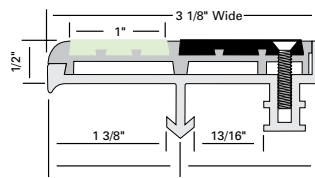

WP-RN3SG-NG

STAIRMASTER® 333-NG

- Stairmaster® 333-NG high-quality lowest cost stair nosing. Easy to install utilizing construction adhesive and predrilled holes.

STAIRMASTER® 333-NG

3" Wide, NITEGLOW® is 1" wide

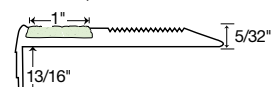

TYPE 333-NG with 1" wide strip of NITEGLOW®

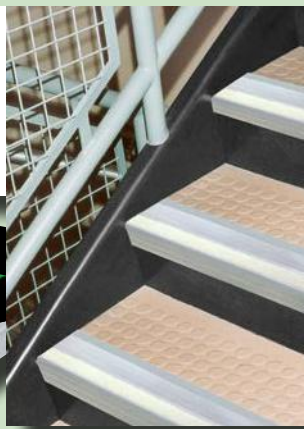

STAIRMASTER® 500-NG

- Stairmaster 500-NG installed on stairways provides safety in two ways, prevents slips and falls and illuminates the front of the stairs for evacuation safety

STAIRMASTER® 500-NG

9" Wide, NITEGLOW® is 1-1/8" wide



TYPE 500-NG with 1-1/8" wide strip of NITEGLOW®

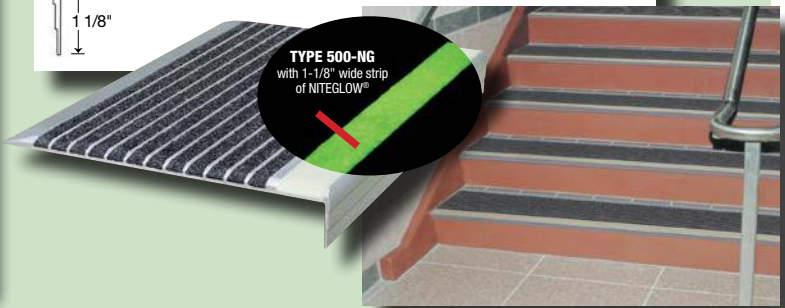

PHOTOLUMINESCENT SIGNS AND TAPES

GLOW TAPE 408.3



GLOW SIGN 40.22



GLOW SIGN 40.10



GLOW SIGN 40.14



GLOW SIGN 40.18

NOT AN EXIT

GLOW SIGN 8.66

NO RE-ENTRY

GLOW TAPE 412.2



GLOW SIGN 40.12



GLOW SIGN 40.16



GLOW SIGN 40.21



25 Year Limited Warranty on Glow. Expect Service life GREATER than 50 years!

* National Safety Council information

9.6 million emergency hospital visits are made per year due to falls*

Specify Abrasive Castings For:

- Maximum Durability in Rough Use
- Indoor or Outdoor Use
- Resistance to Corrosive Environments
- Anti-Slip Safety Properties
- Ready to Install Convenience
- New Construction or Existing Buildings

TREADS, NOSINGS AND THRESHOLDS FOR PROTECTION AND LONG WEAR

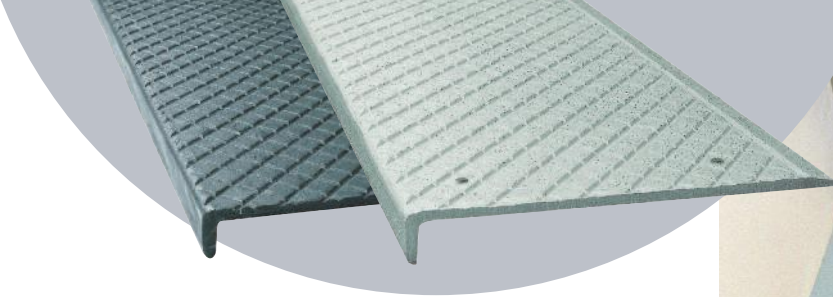

ABRASIVE CASTINGS SPECIFICATION:

Provide Alumogrit® or Ferrogrit® type _____, size _____, safety treads/nosings as manufactured by Wooster Products Inc. for interior and exterior stairs.

- Abrasive shall be #20 virgin grain Aluminum Oxide (AL₂O₃) abrasive, integrally cast into the walking surface to a minimum depth of 1/32 inch (.79 mm).
- Safety nosings up to 6" (152.4 mm) deep with cross-hatched surface being installed into wet concrete shall have a "Marker Line" (Trademark 3571602) along the back edge.
- Concealed type anchors shall be slotted rivet type, integrally cast into the body of the nosing a minimum of 3/8 inch (9.53 mm). (Not mushroom type.)
- Cast metals used shall conform to the following specification:
 - **Alumogrit®** (Abrasive cast aluminum): No. 43 prime and secondary ingot; low copper content; corrosion-resistant.
 - **Ferrogrit®** (Abrasive cast iron): Class 20 iron; high silicon; machinable, hypereutectic.
- All holes or countersinks shall be machine-made. Screwheads shall not protrude above tread surface.
- All metal types shall have shot-blasted finish; Ferrogrit® treads and nosings to have one coat shop-black paint.
- Cross hatching and fluting shall be 1/16 inch (1.59 mm) deep minimum and shall be clean and well defined; treads and nosings shall be manufactured, packed and shipped so as to arrive at the jobsite in good condition.
- Nosings shall terminate not more than 4" (101.6 mm) from ends of steps for poured concrete stairs; for concrete-filled steel pan stairs, nosings shall be full length of steps, less 1/8" (3.05 mm) clearance.

Note: Safety nosings going into fresh poured concrete shall be installed before "Initial Set" of the concrete.

Non-structural stair nosings and treads for Poured concrete and steel pan concrete-filled stairs

FERROGRIT®

- 5/16" thick - nosing max. 6" wide - max. length 8'6"
- 3/8" thick - nosing width to 6" - max. length 8'6"
- 3/8" thick - over 6" to 12" wide - max. length 6'

ALUMOGRIT®

- 5/16" and 3/8" thick - nosing width to 6" - max. length 8'6"
- 3/8" thick - over 6" to 12" width - max. length 6'
- Types 101, 101SP, 100, 102, 110 and 120
- 5/16" thick - over 6" to 12" wide - max. length 6'
- Types 103, 104, 116, 116A and 105A
- 5/16" thick - over 6" to 9" width - max. length 6'



ALUMOGRIT® NOSING

TYPE 116A – GREAT FOR EXISTING INDUSTRIAL STAIRWAYS AND/OR LANDINGS.

Wooster's quality cast treads, nosings and thresholds contain an even distribution of abrasive grit integrally cast into the surface for anti-slip protection and long wear. Width and length to order. Nosings that are set flush generally should be 3" (76.2 mm), 4" (101.6 mm) or 6" (152.4 mm) in width.

SURFACE: Abrasive cross-hatch is standard and will be furnished unless plain or fluted surface is specified. (Cross hatch pattern may not match up on sections being butted together.)

FASTENERS: 1/4" (6.35 mm) F.H.M. plated screws and nuts with steel wing anchors for fresh poured concrete or concealed integral anchors are available.

DRILLING: Standard drilling for nosings 3" (76.2 mm) in from ends and on approximate 12" (304.8 mm) centers in single, staggered or double row according to width. See page 14 for typical Anchor and Installation Details.

DO NOT predrill support structure before tread installation.

LENGTH: Up to 8'6" (2.59 m) in one piece for Alumogrit® or Ferrogrit®. These maximum lengths do not apply to structural treads or platforms. Call Wooster Products for more details on maximum structural sizes.

GUIDELINES FOR THE INSTALLATION OF METAL SAFETY TREADS OR NOSINGS INTO NEW CONCRETE OR STEEL PAN-FILLED STAIRS:

- ... The use of very large aggregate in the concrete mix may make placement of the safety nosing difficult.
- ... Safety nosing placement may be difficult in concrete with very low slump.
- ... Place the concrete into the stair forms or steel pans as quickly as possible; schedule pours so as to install the metal safety nosings quickly, **before the "initial set"** of the concrete occurs.
- ... Puddle the concrete, tamp the safety nosings to insure proper concrete formation around the anchors.
- ... Remove the protective tape as soon as practical.

NOTE: Most nosings, stair treads and other anti-skid products are manufactured to order. Please contact Wooster Products Inc. for current lead time. **Close stairway after pour; permit no use for 24 hours.**

Specify Abrasive Castings For:

- Maximum Durability in Rough Use
- Indoor or Outdoor Use
- Resistance to Corrosive Environments
- Anti-Slip Safety Properties
- Ready to Install Convenience
- New Construction or Existing Buildings

MEETS ADA REQUIREMENTS

Please call Wooster Products Inc for current availability.

These sections available with concealed integral anchors, wing anchors, or countersunk holes (See page 14 for details).

Maximum Piece length is 8 feet

POURED CONCRETE

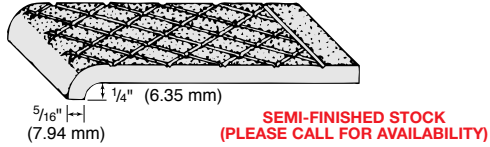

TYPE 101 – Nose 5/16" (6.35 mm) lip.
Chief use: as nosings, formed concrete stairs.
Tread installed flush all around.

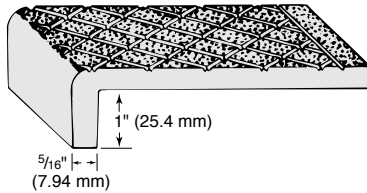

TYPE 116 – Nose depth 1" (25.4 mm) standard.
Chief use: as nosings, formed concrete stairs
where deeper lip is desirable.

FOR EXISTING STAIR REPAIR

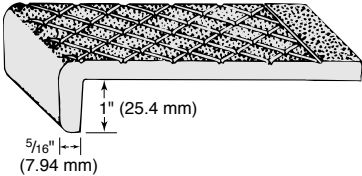

TYPE 116A – Nose depth 1" (25.4 mm) standard.
Chief use: on top of existing steps for repair and
modernization.

STEEL PAN

Generally installed full stringer to stringer length, less 1/8" (3.05 mm) clearance.

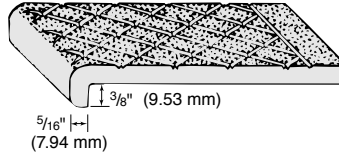

TYPE 101SP – Nose 3/8" (9.53 mm).
Chief use: as nosings on steel-pan
concrete-filled stairs or on existing steps.

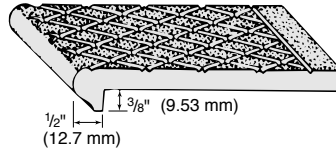

TYPE 102 – Nose 1/2" x 3/8" (12.7 mm x 9.53 mm). Chief use: as nosings on
steel-pan stairs. Can also be used
structurally with bent-plate risers.

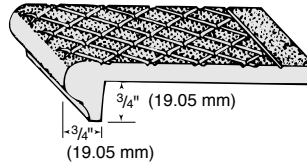

TYPE 103 – Nose 3/4" x 3/4" (19.05 mm x 19.05 mm). Chief use: as structural treads
with bent-plate risers or as nosings full
width of stair.

MISCELLANEOUS USES



TYPE 100
Square edges. Chief uses: floor plates,
trench covers, stair landing platforms,
expansion joint covers.

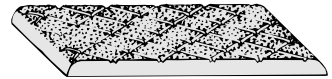

TYPE 110
Rounded edges. Chief uses: Expansion
joint covers, platforms around
machinery, deck treads.

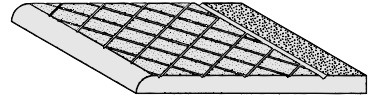

TYPE 120
One edge rounded. Chief use: nosings
on steel grating treads and for special
conditions, usually superimposed.

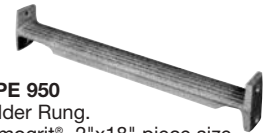

TYPE 950
Ladder Rung.
Alumogrit® 2"x18" piece size

CONCRETE CURBS

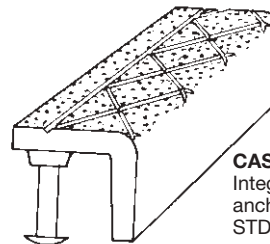

CAST:
Integral
anchors
STD

TYPE 150
1 1/2" x 1 1/2" x 3/8"
(38.1 mm x 38.1 mm x 9.53 mm)
Maximum length 6'0" (1.83 m)

TYPE 250
2 1/2" x 2 1/2" x 1/2"
(63.5 mm x 63.5 mm x 12.7 mm)
Maximum length 6'0" (1.83 m)
(Steel Anchor ONLY)

Consult factory when holes for fastening are required.

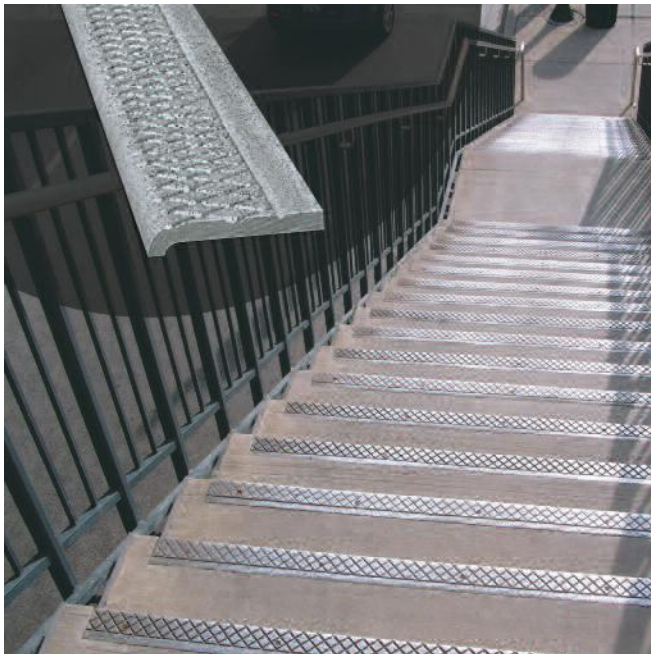

- Ferrogrit® is not recommended for corrosive environments.
- Ferrogrit® is not recommended for outdoor use due to possible rust appearance.
- Castings are subject to usual foundry draft, tolerances and thickness ± 1/8".
- Nosings may show a parting line on the nose surface.
- Standard measurements are from top of the leading edge.
- Custom lengths to ± 1/16".
- Standard hole size 1/4" with countersunk hole tops.
- Standard depths; 3", 4" and 6"
- Standard drilling; 3" from ends on approximately 12" centers.
- Beveled treads. Contact factory on availability per application.
- Lengths over maximum to be made in equal sections.

WP ABRASIVE CAST STRUCTURAL Ferrogrit® and Alumogrit® Treads, Platforms & Cast Thresholds

Specify Abrasive Castings For:

- Maximum Durability in Rough Use
- Indoor or Outdoor Use
- Resistance to Corrosive Environments
- New Construction or Existing Stairs
- Ready to Install Convenience
- Anti-Slip Safety Properties
- Extreme Field Conditions

TREADS, NOSINGS AND THRESHOLDS FOR PROTECTION AND LONG WEAR



**FERROGRIT®
STRUCTURAL TREADS**

NOTE: Thicknesses are minimum for casting purposes and not always sufficient for structural strength. Where width exceeds 18" (457.2 mm), maximum piece length 6'0" (1.83 m). Where width exceeds 38" (965.2 mm), maximum piece length 5'0" (1.52 m). Color may vary from piece to piece for all metals. Cross-hatched, or flutes may not match when multiple sections are used.

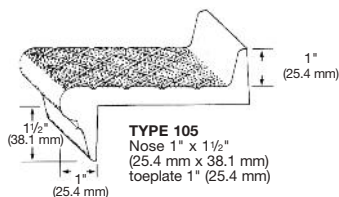

TYPE 105
Nose 1" x 1 1/2"
(25.4 mm x 38.1 mm)
toeplate 1" (25.4 mm)

Chief use: as structural treads. Nosing and toeplate can be drilled for attaching flat plate risers, when specified.

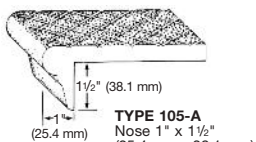

TYPE 105-A
Nose 1" x 1 1/2"
(25.4 mm x 38.1 mm)

Chief use: as structural treads or front of landing.

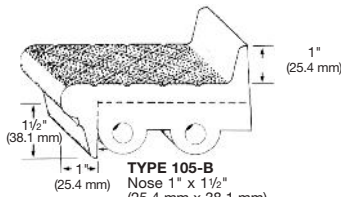

TYPE 105-B
Nose 1" x 1 1/2"
(25.4 mm x 38.1 mm)

Chief use: as structural treads. Nosing and toeplate can be drilled for attaching flat plate risers, when specified.

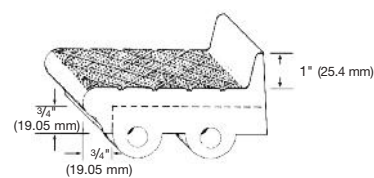

TYPE 107

Chief use: as structural treads. Nosing and toeplate can be drilled for attaching flat plate risers, when specified.

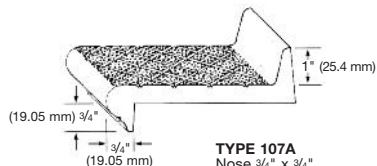

TYPE 107A
Nose 3/4" x 3/4"
(19.05 mm x 19.05 mm), toeplate 1" (25.4 mm)

Structural tread fastened to carrier angles on stringers.

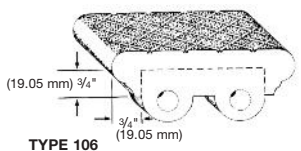

TYPE 106
Double nose tread, reversible. End lugs provided for bolting treads directly to stringers.

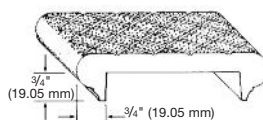

TYPE 106A

Double nose tread, reversible. Chief use: as structural tread supported by carrier angles on stringers.

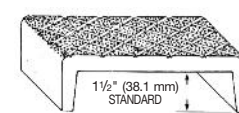

TYPE 117

Double nose tread, reversible. Chief use: as structural tread fastened to carrier angles on stringers.

TYPE 117A

Double nose, reversible. Chief use: marine and industrial ladders. Treads bolt directly to stringer.

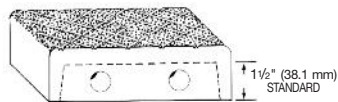

TYPE 104
Nose 1" x 1"
(25.4 mm x 25.4 mm)

Chief use: as structural treads with bent-plate risers or superimposed on existing steps.

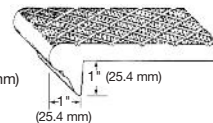

MINIMUM THICKNESS TABLE FOR DRILLING ON STRUCTURAL TREADS

SPAN	To 4' 0"	To 5' 0"
All Metals	1/2" (12.7 mm)	5/8" (15.88 mm)

NOTE: Thicknesses are minimum for casting purposes and not always sufficient for structural strength.

STANDARD HOLE SPACING FOR TREADS WITH LUGS

Hole spacing for self-supporting treads. Maximum length 5'0". All treads are cast with truss ribs when required.

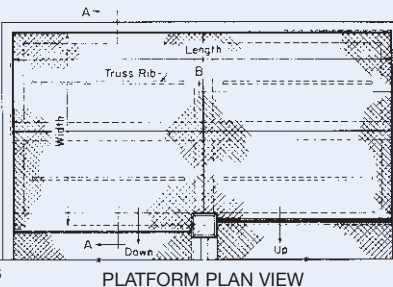
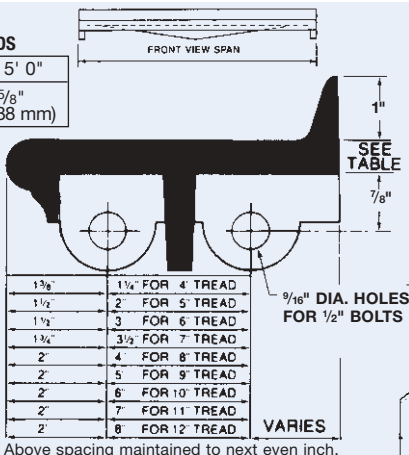

PLATFORM PLAN VIEW

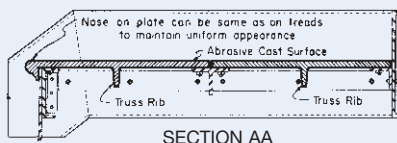

SECTION AA

NOTE:

- Platforms manufactured in sections.
- Toeplates are added as required.
- Matching nosings are used on treads and platforms.
- Truss ribs are added when required for structural strength.
- Ferrogrit treads and platforms are furnished painted black; other metals have shotblasted finish.
- Standard surface furnished is abrasive cross hatched. Plain and fluted surfaces are also available.
- Supporting structural steel and fasteners are "by others".
- Various tread styles are available for attaching to carrier angles, or bolting directly to stair stringers.
- Sections are not "to scale".
- Attachment hole spacing for treads and platforms is "as detailed" for each job.
- Structural treads are custom made per application.
- Maximum structural tread length 5'0"

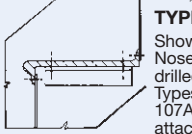

TYPE 105

Shown attached to carrier angles. Nose and toeplate have been drilled for closed riser plates. Types 103, 104, 105A, 105, 106A, 107A, and 117 can be drilled for attachment to carrier angles.

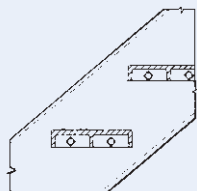

TYPE 117A

Shown with end lugs for mounting directly to stair stringer. No carrier angles are required. Types 105B, 106, 107, and 117A can be used this way.

WP ABRASIVE CAST STRUCTURAL Ferrogrit® and Alumogrit® Treads, Platforms & Cast Thresholds

Specify Abrasive Castings For:

- Maximum Durability in Rough Use
- Indoor or Outdoor Use
- Resistance to Corrosive Environments
- New Construction or Existing Stairs
- Ready to Install Convenience
- Anti-Slip Safety Properties
- Extreme Field Conditions

MEETS ADA REQUIREMENTS

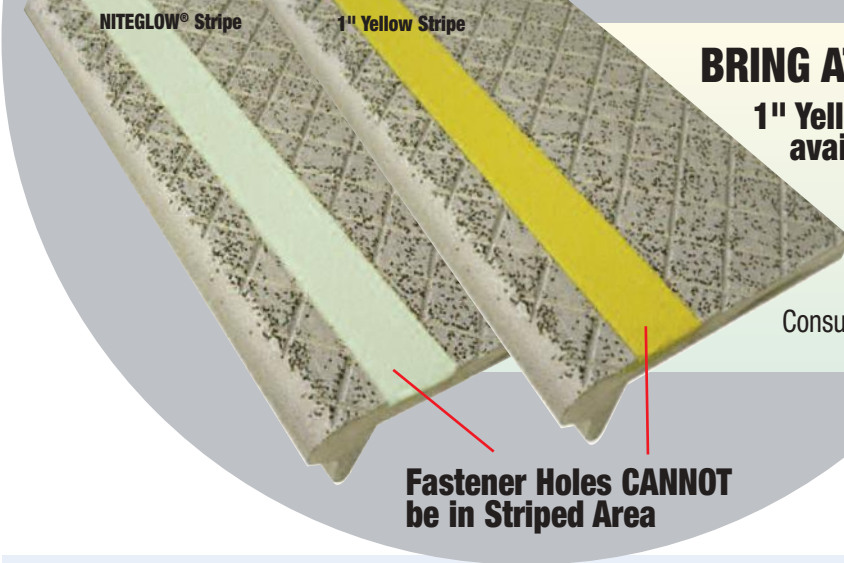

BRING ATTENTION TO EDGE OF THE STEP!

1" Yellow Stripe or NITEGLOW® Stripe available on nosing or treads.

Nosings or treads **MUST BE** at least 3/8" thick and at least 4" wide.

Available in Alumogrit ONLY!

Consult factory for stripe location and additional cost.

Fastener Holes **CANNOT** be in Striped Area

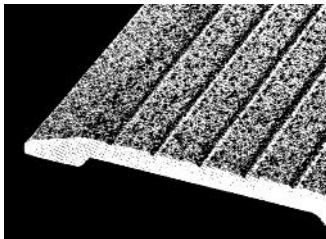

FLUTED SURFACED THRESHOLD

"Wooster" abrasive cast thresholds are cast to order from a large selection of architectural designs as shown. They are of highest quality and heavy duty construction in these metals:
ALUMOGRIT®: abrasive cast aluminum
FERROGRIT®: abrasive cast iron
FASTENERS: Thresholds are drilled and countersunk for 1/4" (6.35 mm) screws unless other fasteners are specified.
NOTCHING: Threshold ends can be factory notched for fast jobsite installation if frame details are furnished.
SPECIFICATIONS: See page 10 for casting specifications.
LENGTHS: Lengths to order up to 8' 6" (2.59 m) maximum in one piece.
SPECIAL PROFILES: Special shapes up to 18" (457.2 mm) are available if details are provided.

*Meets A.D.A. Requirements

* National Safety Council information

SADDLE TYPES*

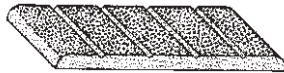

TYPE 110 - Widths and heights as required. Fluted, plain, or cross hatch surface 3/4" (9.53 mm) thick.

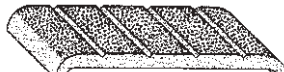

TYPE 111 - Standard 4" (101.6 mm), 5" (127 mm), 6" (152.4 mm) widths. Standard height 1/4" (14.29 mm), surface fluted. Other widths and heights to order.



TYPE 114 - Standard 4" (101.6 mm), 5" (127 mm), 6" (152.4 mm) widths. Standard height 3/8" (9.53 mm), surface fluted. Other widths and heights to order.



TYPE 115 - Standard 4" (101.6 mm), 5" (127 mm), 6" (152.4 mm) widths. Standard height 1/2" (12.7 mm). Other widths and heights to order. Fluted surface.

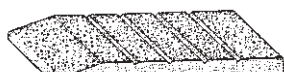

TYPE 115M - Standard 4" (101.6 mm), 5" (127 mm), 6" (152.4 mm) widths. Standard height 1/2" (12.7 mm). Other widths and heights to order. Fluted surface.

STOP TYPES

(50.8 mm for 101.6 mm, 12.7 mm widths)
2" for 4", 5" widths
2 1/2" for 6" width
(63.5 mm for 152.4 mm width)



TYPE 112 - Standard 4" (101.6 mm), 5" (127 mm), 6" (152.4 mm) widths. Height under door 1/4" (16 mm). Other heights and intermediate dimensions to order. Plain surface.

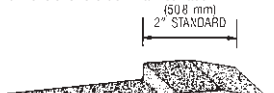

TYPE 113 - Standard 4" (101.6 mm), 5" (127 mm), 6" (152.4 mm) widths. Height under door 1/4" (22.23 mm). Other heights and intermediate dimensions to order. Plain surface.

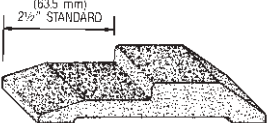

TYPE 115S - Standard 4" (101.6 mm), 5" (127 mm), 6" (152.4 mm) widths. Height under door 1/2" (12.7 mm). Other heights and intermediate dimensions to order. Plain surface.

HOOK STRIP TYPES

Styles of Hookstrip furnished with Types 109 and 119 thresholds. Specify style.

STYLE J STYLE L



TYPE 109
Standard 4" (101.6 mm), 5" (127 mm), 6" (152.4 mm) widths. Other widths to order. Made in 1/2" (12.7 mm). Other heights and intermediate dimensions to order. Fluted surface.



TYPE 119
Standard 4" (101.6 mm), 5" (127 mm), 6" (152.4 mm) widths. Other widths to order. Made in 3/4" (16 mm), height only. Fluted surface. Hookstrip for door included.

TYPICAL INSTALLATIONS

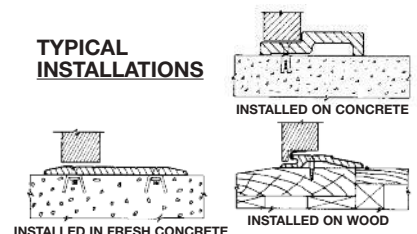

FRESH CONCRETE

SURE-HOLD ANCHOR

Sure-Hold anchors run full length of tread for positive anchorage and quick installation. Since Sure-Hold anchors are concealed, no bolt holes appear on the tread surface. Available as shown on nosings.

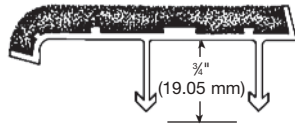

WING TYPE ANCHOR FOR CAST AND EXTRUDED NOSINGS

Steel wing anchors, bolts, and nuts are furnished for field attachment into factory-drilled and ctsk. holes, prior to tread installation, from ends on approx. 12" (304.8 mm) centers. In single, staggered or double row, according to tread width. Can be furnished on most types if specified. 3/4" length - FHMS. Wing metal, standard mild steel. Stainless steel upon request. Tapcon screws also available for cast nosings and treads

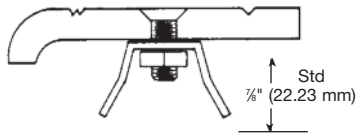

CONCEALED INTEGRAL ANCHOR

This concealed type anchor is furnished standard on cast types 150 and 250. Anchor spacing on approx. 10" (254 mm) centers. Can be furnished on types 101, 101-SP, 116, 102, 103, 104, 105A, 100 but MUST BE SPECIFIED.

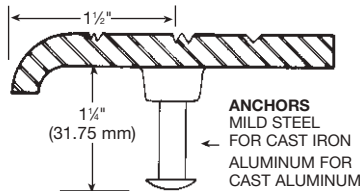

EXISTING CONSTRUCTION

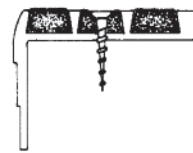

WOOD OR MACHINE SCREWS



SILVER TAPCON SCREWS

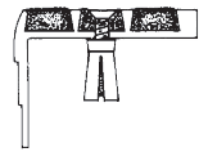

SCREW & SHIELDS

Treads being superimposed on existing stairs can be furnished pre-drilled and ctsk. for wood, machine or Tapcon screws. Standard spacing is 3" (76.2 mm) in from each end, approx. 12" (304.8 mm) centers, in single, staggered, or double row, according to tread width. Will furnish #10 screws.

BOLTED TO STEEL PAN RETURN

Nut and Bolt anchorage can be provided for new steel pan stairs. Pan return must be 1" (25.4 mm) minimum. Specify pan return depth for drilling purposes. Can be furnished on types WP-2, WP-RN2SG, WP-RN2SP, WP-RN3SG, WP-RN3SG-NG, WP-3, WP-RN3SG, WP-RN3SP, WP-RN3SG-NG, WP-RN3SP-NG, 122, 132, 138, 142, 133, 162, 101-SP, 102, 103, but MUST BE SPECIFIED. Standard hole spacing is 3" (76.2 mm) from ends on approx. 12" (304.8 mm) centers.

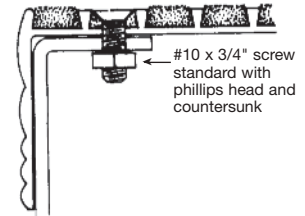

ALSO AVAILABLE: PROTECTIVE TAPE

Nosings for NEW construction can be furnished with protective tape. This tape should be removed after the stairs are installed. Tape coverings entail a small additional charge per lineal foot. Tape should not be left on treads longer than 45 days.

MUST BE SPECIFIED; Consult Factory

INSTALLATION DETAILS

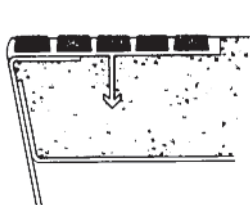

TYPE 231 BF Sure-Hold anchor in sloped riser steel pan step.

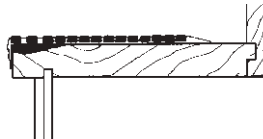

Type 500 Stairmaster® installed on wood step (wood screws available). If steps are other than wood, use screws with expansion shield or nut and bolt or Tapcon screws and an application of construction adhesive.

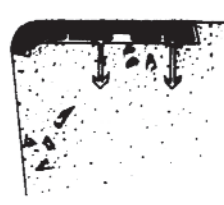

Type WP3C with integral Sure-Hold anchor in new concrete stair.

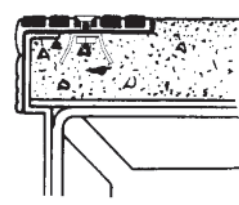

Type 133 Supergrit® with wing anchors in concrete filled steel pan.



Type 101 with wing type anchors in poured concrete stair.



Type 101SP with concealed integral anchor in steel pan stair.

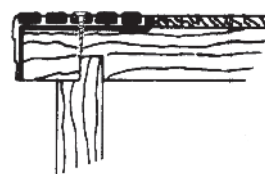

Type 142 Supergrit® attached to wood tread and backed with tile, carpet, or other material.

- Heavy Pedestrian Traffic
- Indoor, Outdoor Installation
- Excellent Safety Protection at Low Cost
- For Existing Stairs
- Non-combustible



**SPECIFY
“STAIRMASTER”
FOR WORN AND SLIPPERY STAIRS**

Stairmaster® Safety Treads are designed for the modernization and restoration of all types of stairs, while also providing excellent anti-slip protection.

Two-tone treads with contrasting color available.

Stairmaster® Safety Treads provide a fast and economical alternative to removal and reconstruction of a stairway.

Wooster Products Leveling Compound is available to fill/level worn steps before installing Stairmaster® treads.

Use construction adhesive in addition to mechanical fasteners for the best installation results.

See page 3 for material specifications.

- Special tread sealer available for wood or saltwater applications.

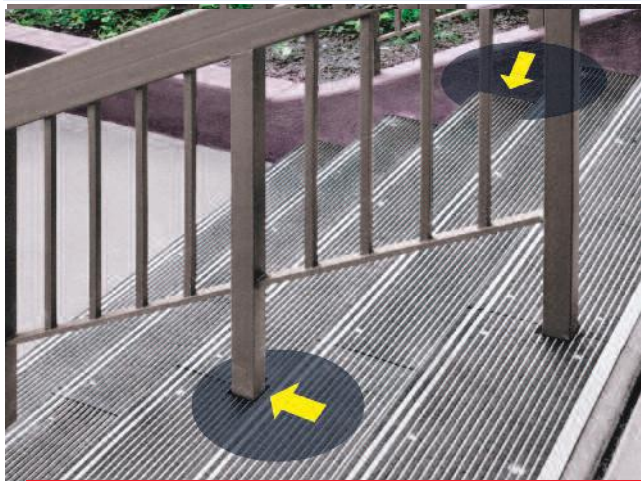

STAIRMASTER® ON CONCRETE STAIR, CUT TO FIT AROUND THE POST & THE LENGTH OF THE STAIR WITH SQUARE ENDS.



STAIRMASTER® ON WOOD STAIR, CUT SHORTER THAN THE LENGTH OF THE STAIR WITH BEVELED ENDS.

Most styles available up to 12'0" in one section. Maximum piece length on type 333, 6100, 511SN and 511 is 8'0". Drilled and countersunk holes are standard unless otherwise specified. Beveled ends, countersunk holes and tapcon screws are standard, unless specified.

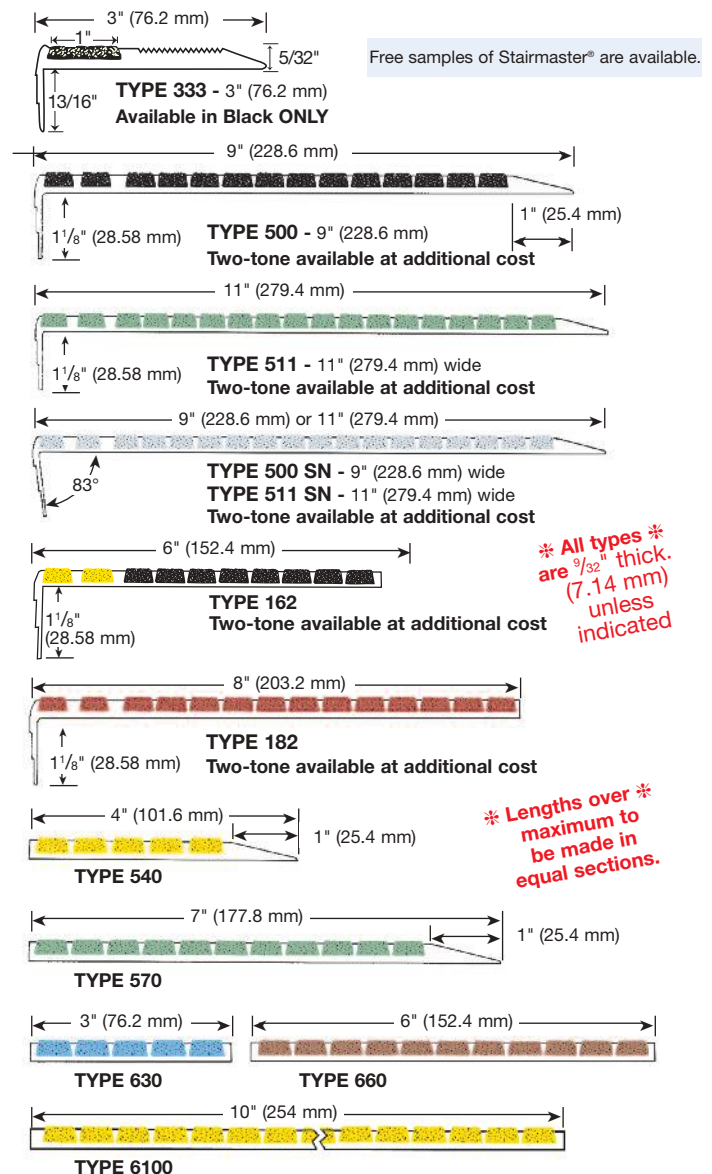

EXISTING BUILDINGS



“STAIRMASTER” Coverage of Landings

Full or partial coverage can be provided on landings.

Use treads below to cover depths greater than 11 inches. In addition to landings, treads can be used for applications like floors behind cafeteria counters, door sills, ramps, floor divisions, industrial platforms and in front of machines.

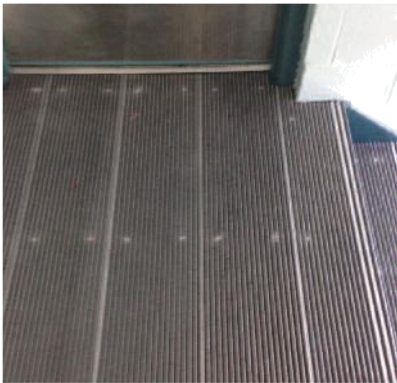

EXAMPLES OF TREAD TYPES USED TO COVER A LANDING



TYPES OF LANDINGS

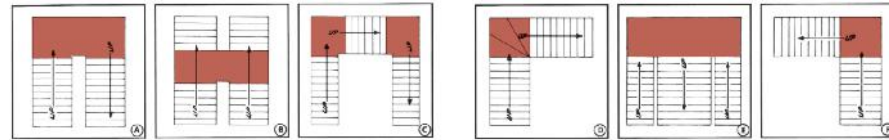

AVAILABLE STAIRMASTER® COLORS

Standard color is black. Black will be shipped unless another color is specified. See color chart below for other colors available.



Actual tread color may vary slightly from printed sheet. Request tread sample if color is critical.

LEVELING COMPOUND



Leveling Compound is supplied in 50-lb pails and consists of specially formulated components. Just add water, mix and compound is ready for troweling. It will not shrink as it dries and can be featheredged. One drum covers 50 square feet of surface in 1/8" thickness. Compound adheres to most surfaces; wood, concrete, steel, marble, etc. No primer required.

HEAVY DUTY CONSTRUCTION ADHESIVE

- 12 - 10.5 oz. cartridges per case
- VOC Compliant
- Use in addition to mechanical fasteners
- Coverage 70 lineal feet of tread per case, 5/16" bead



WP FLEXMASTER® SAFETY TREADS

- Inexpensive
- Easily replaceable
- Color coordinated surfaces available
- Title 24 applicable
- A.D.A. approved
- Durable safety surface

- NITEGLOW® available
- Indoor/outdoor use

3-Year Warranty
on material and workmanship.

FLEXMASTER® treads beautify and protect worn or slippery stairs.

Sizes Available: • Type #365, 6-1/2" wide • Type #300, 9" wide • Type #311, 11" wide

- Treads are furnished drilled and countersunk unless otherwise specified.
- Specify construction adhesive for installation. • Maximum length = 12' 0"

Flexmaster -this state of the art design is: inexpensive, easy to install, ADA approved, title 24 applicable, easily replaceable.

The tread base is made of Alloy 6063-T5 extruded aluminum, with a 5/32" thickness minimum. All exposed aluminum will have a satin-lacquered finish. Color extends uniformly throughout the abrasive surface; available in any Flex-Tred color.

- Reduce Liability Claims
- Promote Pedestrian Safety
- Durable
- Meet OSHA & ADA Safety Regulations
- Reduce Lost-time Accidents Quickly
- Long Lasting

FLEXMASTER® is available with NITEGLOW® Glow-In-The-Dark anti-slip surface.

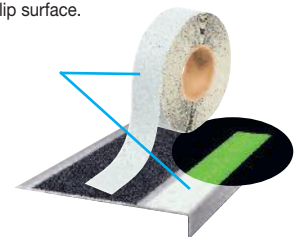

Not MEA or IBC Approved

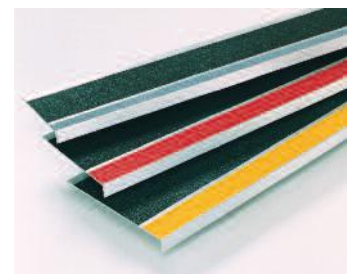

No additional cost for two color.

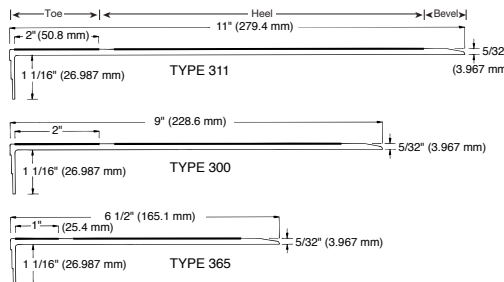

EXISTING BUILDINGS



FLEX-TRED®

Anti-Slip Safety Rolls, Cleats & Strips for Indoor or Outdoor Use

FLEX-TRED®

Flex-Tred® heavy-duty safety surface is quick to install and provides durable pedestrian safety on slippery surfaces. Uses: ramps, light traffic stairs, exercise equipment, industrial equipment, aisles, entrances, skateboards.

Flat black medium is a standard color and will be furnished unless another color is specified.

Black Textures: Sparkle Black, Ultragrip Black, Flat Black Extra Coarse, Flat Black Coarse, Flat Black Medium, Marine Black, Flat Black Fine, Super Fine Black.

General Note: Standard tolerance $\pm 1/16"$

STANDARD ROLL SIZES

3/4" x 60 ft. - packed	16 rolls per carton
1" x 60 ft. - packed	12 rolls per carton
2" x 60 ft. - packed	6 rolls per carton
3" x 60 ft. - packed	4 rolls per carton
4" x 60 ft. - packed	3 rolls per carton
6" x 60 ft. - packed	2 rolls per carton
8" x 60 ft. - packed	3 rolls per carton
12" x 60 ft. - packed	1 roll per carton
18" x 60 ft. - packed	1 roll per carton
24" x 60 ft. - packed	1 roll per carton

STANDARD DIE-CUT SIZES

All standard sizes are packed 50 pieces each carton.

STRIPS AND CLEATS STANDARD CUT SIZES:

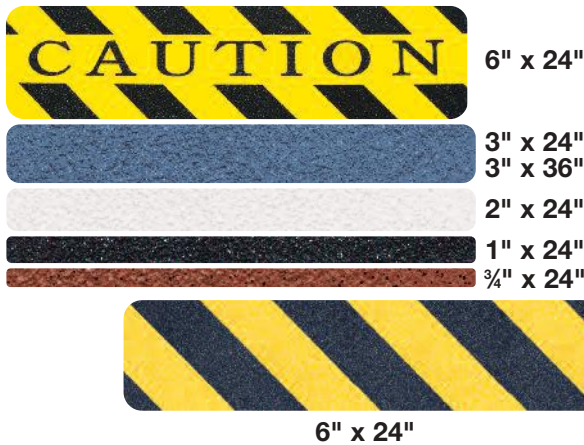

Custom Sizes On Request
Standard tolerance + - 1/16"

Custom sizes for rolls and die cuts available by request.



Wooster Products Floor Prep

Wooster Floor Prep is an effective alkaline compound recommended for cleaning all types of floor surfaces, prior to applying Flex-Tred®. Coverage: Each 4 oz. bottle will clean approximately 50 sq. ft.



Wooster Products Clear Edge Sealer

Wooster Products clear edge sealing compound is used in applications where Flex-Tred exposure to liquids is expected. Fast drying (dries overnight) edge sealer sticks to most surfaces including metal, wood, rubber, plastics, concrete and fiberglass. Each 5 oz. tube covers approximately 100 lineal feet when applied as a 3/16" bead.



Seam Roller

Use on seams or edges, or to eliminate bubbles.



MOP FRIENDLY MARINE & POOL COLORS

With a special design for bare feet, Flex-Tred®'s abrasive surface is adhesive backed, economical and easily installed. Special shapes available for OEMs. Ready for immediate use on pool decks, ramps, pleasure crafts, fishing docks, and boats. Order from our standard size rolls, standard die-cut sizes, or custom order your own die cut shape.



Teak Brown

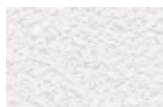

Pebble White

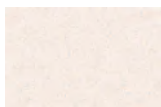

Clear Fine



Marine Black

Use edge sealer for wet environments.

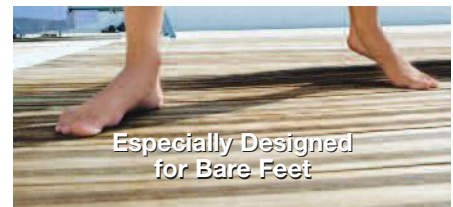

FLEX-TRED® COLOR CHART

Color coordinate with Flex-Tred® – key to decor – show contrast. Our variety of colors gives you a variety of options. Grades of coarseness, available only in black.



Industrial Red



Industrial Brown



Ocean Gray



Striped Safety



Camouflage

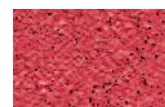

Scarlet Red



Safety Yellow



Standard Black



Fire Orange (fluorescent)



Aurora Pink (fluorescent)



Signal Green (fluorescent)



Saturn Yellow (fluorescent)



Horizon Blue (fluorescent)

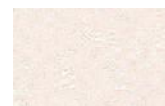

Clear Coarse



NITEGLOW® Glow in the Dark



Caribbean Blue

*Actual color may vary slightly from printed sheet. Request sample if color is critical.

* National Safety Council information

Workers Comp average claim from falls cost \$41,500*

EXISTING BUILDINGS



FLEX-TRED®

Anti-Slip Safety Rolls, Cleats & Strips for Indoor or Outdoor Use

APPLICATIONS

Anywhere You Need an Anti-Slip Surface

Walkways

- stairs • entrances • ramps • docks • pool areas • porches
- decks • balconies • ski-lift access areas • catwalks
- patios • galleys • etc.



Product

- recreational vehicles (campers, motor homes, trailers)
- exercise equipment • lawn and garden equipment
- lift trucks • ladders • trucks • construction equipment
- farm tractors and equipment
- playground equipment • skateboards • skis
- spas • utility vehicles • boats • aircraft
- baggage handling equipment • snowmobiles
- golf carts • bumpers • running boards • etc.

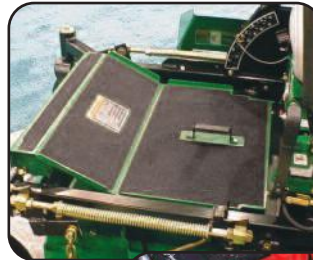

Workplace

- around work benches • laundries
- machinery work stations • kitchens
- platforms • scaffolds • cherry pickers
- boiler and furnace areas • etc.

GENERAL PROPERTIES

- **Flexibility** - Flex-Tred® bends over sharp 90° angles without fracture. Repeated bending without cracking or failure of bond.
- **Temperature Limits** - Applied Flex-Tred® has a useful temperature range of -40°F to 220°F. However, limited exposure to temperatures above 220°F will not harm Flex-Tred®.
- **Steam Cleaning** - Applied Flex-Tred® will tolerate steam cleaning.
- **Detergent Cleaning** - Applied Flex-Tred® will tolerate detergent cleaning.
- **Environmental Resistance** - Flex-Tred® is essentially unaffected by climactic exposure and mild acid or alkali exposure under normal conditions.
- **Shelf Life** - Flex-Tred® shelf life is two years minimum.

BENEFITS

- **Anti-slip** wet or dry
- **Reduces liability** exposure
- **Quick & Easy to Install**
- **Economical**
- **Durable** - long wearing
- **Super Adhesion**
A heavy coating of specially formulated pressure-sensitive adhesive
- **Resistant to Solvents**
- **Die Cuts** available to fit your application.
- **Colors available**

FLEX-TRED® Improves Coefficient of Friction of Most Surfaces in Wet or Dry Use

Coefficient of friction tests run per specification Mil-D-17951C (ships) using rubber test vehicle. Higher numbers indicate better coefficient of friction.

COMPARISON OF VARIOUS SURFACES: STATIC COEFFICIENT OF FRICTION

	Dry Surface Test Results	Wet Surface Test Results		Dry Surface Test Results	Wet Surface Test Results
FLEX-TRED® Surfaces			Other Surfaces		
Flat Black Coarse	1.33	1.21	Ribbed Rubber	.89	.76
Sparkle Black	1.24	1.06	Scotch Tred	.69	.50
Blue Medium	1.29	1.09	Painted Steel	.77	.69
Flat Black Fine	1.37	1.17	Textured Vinyl	.80	.64
Ocean Grey	1.30	1.02	Ribbed Vinyl	.85	.72

Flex-Tred® meets or exceeds specifications for: Mil-D-17951E (ships); Motor Vehicle Safety Standard No. 302; Walkway Matting, Non-slip Mil-W-5044C, Type IV, ADA, ASTM and OSHA.

WP Safety Coating Systems

PAINT

SAFE-STRIDE®

Moderate Traction and Durability for Foot Traffic

- Meet OSHA and ADA standards
- Meet ASTM slip resistance requirements.
- Indoor and Outdoor Applications • Custom Colors Available
- Coatings contain aluminum oxide or zirconium grit which give the coatings long-lasting added traction.

LOW VOC ACRYLIC

- Durable traction grit
- Adheres to concrete, wood, primed metal, asphalt, marble, and stone
- Easy application
- Easy clean-up
- Apply with brush or paint roller



OIL BASE

- Durable traction grit
- Use preferred over acrylic for heavier traffic surfaces
- Easy application
- Apply with brush or paint roller



Black



Gray

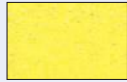

Safety Yellow



Gray



EPOXY COATINGS

WALK-A-SURED® & EPOXY WP-70®

VOC FREE WALK-A-SURED® High Traction and Durability for Vehicle and Foot Traffic

LOW VOC EPOXY WP-70® Extreme Traction and Durability for Industrial Traffic

- Meet OSHA and ADA standards • Meet ASTM slip resistance requirements.
- Indoor and Outdoor Applications • Custom Colors Available
- Coatings contain aluminum oxide or zirconium grit which give the coatings long-lasting added traction.

WALK-A-SURED® CLEAR

- Chemical, solvent and water resistant
- Enhances traction on a variety of surfaces
- 100% solids - **NO VOCS!**
- 2-part Epoxy system
- Barefoot friendly available

WALK-A-SURED® ROLL-ON

- Chemical, solvent and water resistant
- Enhances traction on a variety of surfaces
- 100% solids - **NO VOCS!**
- 2-part Epoxy system



Clear



Black



Gray



UV RESISTANT



EPOXY WP-70®

NO FLASH OR VOLATILE SOLVENTS LOW VOC TROWEL-ON

- 2-part Epoxy system for durable, long-lasting solution
- For industries such as breweries, canneries, off-shore drilling platforms
- Renews damaged ramps and floors in one coat.
- Extra thick consistency requires trowel or squeegee application



Black



Safety Yellow



Gray



Brown



WP COATINGS

	Colors Available	Container Size	Storage Application	Approximate Coverage Sq. Ft.	Cure Time at 75° F	Method of Application	Application Temp.	Working Temp.	Pot Life Minute	Approximate Coefficient of Friction Dry	Approximate Coefficient of Friction Wet	Meets OSHA ADA & USDA Guidelines
PAINT COATINGS MODERATE TRACTION AND DURABILITY FOR FOOT TRAFFIC												
LOW VOC SAFE-STRIDE® Acrylic	Black, Gray, Safety Yellow	1 Gallon	50° to 90°	100-125	2-4 hrs.	1/4" Nap Roller	50° to 90°	130°	N/A	.97	.79	Yes
SAFE-STRIDE® Oil-Base	Gray	1 Gallon	50° to 90°	100-125	12 hrs.	1/4" Nap Roller	50° to 90°	130°	N/A	.87	.83	Yes
EPOXY COATINGS • VOC FREE WALK-A-SURED® HIGH TRACTION AND DURABILITY FOR VEHICLE AND FOOT TRAFFIC												
LOW VOC EPOXY WP-70® EXTREME TRACTION AND DURABILITY FOR INDUSTRIAL TRAFFIC												
VOC FREE WALK-A-SURED® Clear	Clear	1 Gallon Kit	65° to 80°	125-175	18-24 hrs.	1/4" Nap Epoxy Roller	50° to 120°	180°	30-60	.97	.80	Yes
VOC FREE WALK-A-SURED® Roll-On	Black, Gray	1 Gallon Kit	65° to 80°	125-175	18-24 hrs.	1/4" Nap Epoxy Roller	50° to 120°	180°	30-60	.97	.80	Yes
LOW VOC EPOXY WP-70®	Black, Gray, Brown, Safety Yellow	1 Gallon Kit	65° to 80°	25-35	18-24 hrs.	Squeegee	40° to 100°	-40° to +180°	30-60	.92	.76	Yes

No extra hazardous shipping charges, with the exception of Safe-Stride® oil base. Epoxies and oil base Safe-Stride® cannot ship by air.



Sports Stadiums



**Serving You
Since 1921!**



Custom Cutting

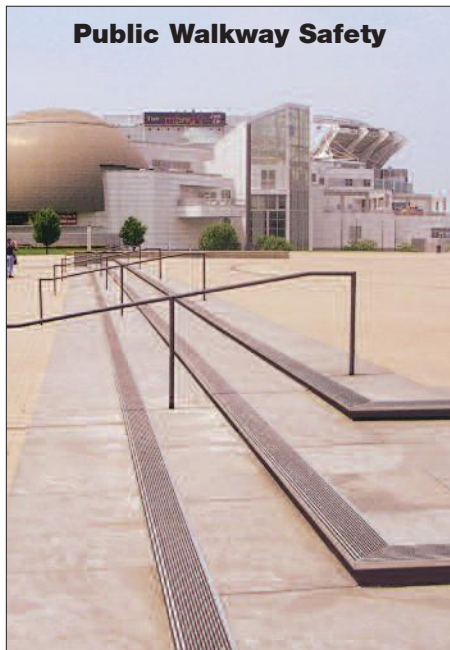

Public Walkway Safety



OEM Supplier



**Wet or Dry Anti-Slip
Public Access**



Marine Anti-Slip Safety

© Copyright 2014 WOOSTER PRODUCTS INC

WOOSTER PRODUCTS INC

1000 Spruce Street • P.O. Box 6005
Wooster, Ohio 44691

Phone: (330) 264-2844 • Fax: (330) 262-4151
Toll Free Phone: 1-800-321-4936

**Application Consulting:
refer to website for local support**

Web Site: <http://www.wooster-products.com>
E-Mail: Sales@wooster-products.com

See Sweets Catalog, Blue Book and Thomas Register



Printed in U.S.A.

Wooster Products Inc. reserves the right, without notice, to make changes in specifications, construction or design of any products at any time in such manner as we may consider necessary, or advisable, and to discontinue the manufacture and sale of any products.

IMPORTANT NOTICE TO PURCHASER: THE FOLLOWING IS MADE IN LIEU OF ALL WARRANTIES, EXPRESSED OR IMPLIED, INCLUDING WARRANTIES OF MERCHANTABILITY AND FITNESS FOR A PARTICULAR PURPOSE: Purchase or use of this product constitutes an agreement with Seller and Manufacturer that, if the product proves to be defective or in any way unsuitable, Seller's and Manufacturer's limit of liability for all damages, including but not limited to incidental or consequential damages, and User's or Purchaser's exclusive remedy, regardless of legal theory, including theories of breach of warranty, negligence and strict liability, shall be to receive, at Seller's or Manufacturer's option, repair of the defective product, an equivalent quantity of replacement product or a refund of the purchase price.