

# WindMaster 3015K Portable Sign Stand

Corrosion resistant and tested to withstand 500 hours of salt spraying, the Windmaster Sign Stand 3015K is engineered with the highest quality materials and has been thoroughly tested to ensure maximum performance.

Sign stands securely hold roll-up signs of all standard shapes and styles, including rectangular, octagonal, triangular, and diamond shape and accommodate sign sizes up to 16 sq. ft.

Sign stands have four telescoping legs capable of accommodating uneven terrain surfaces. Each leg come with a steel kick release pin and spring mechanism completely enclosed within that can be easily released by pushing the kick-release pin with your hand or foot.

While in normal operating position, legs of the sign stand are able to withstand being run over by a 3500-pound vehicle on asphalt or concrete road surfaces.

Two coil springs mounted vertically prevent twisting and ensure stability with 120,000-PSI tensile self-locking bolts.



*Roll-up signs and cross-ribs sold separately*



**Meets All OTM Book 7 Requirements**



**Stinson** TRAFFIC SAFETY  
SPECIALISTS

Get expert advice or place an order at  
**stinson.ca | 1-800-561-6639**

# WindMaster 3015K Components

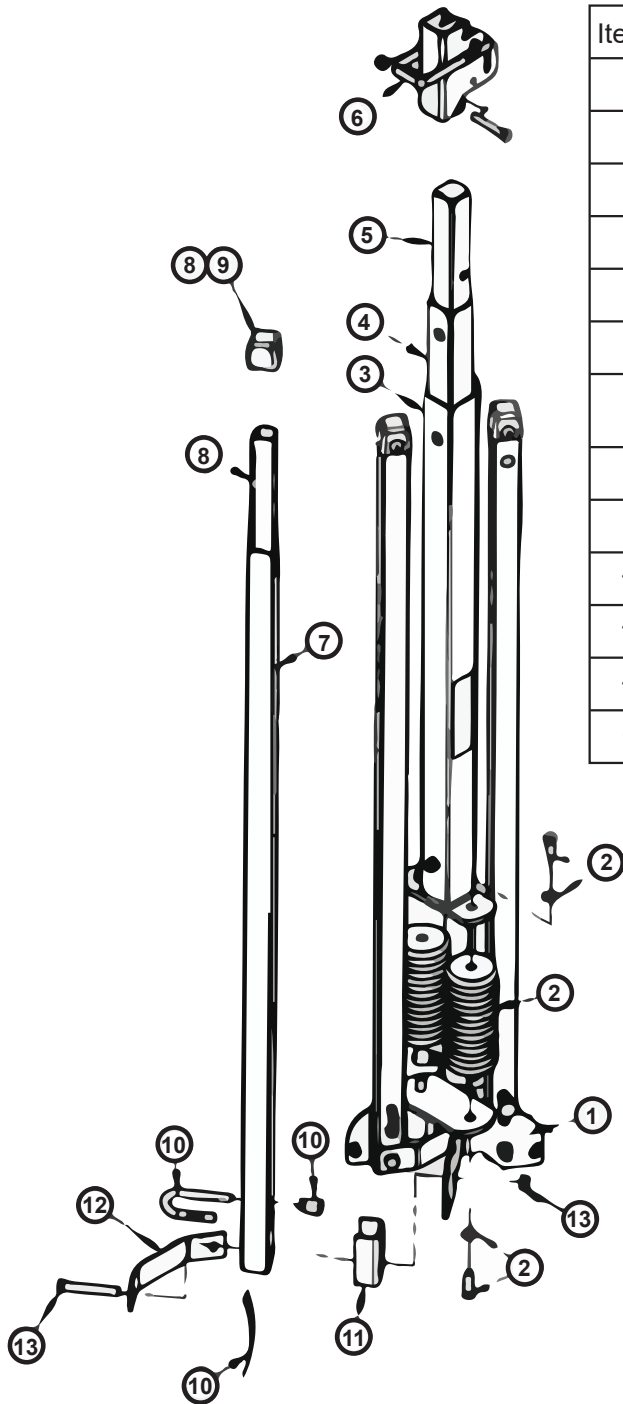

Item #	Description
1	Sign Stand Base
2	Spring Assembly (One Spring & Hardware Kit)
3	Bottom, Stationary Upright
4	Middle Telescoping Upright
5	Top Telescoping Upright
6	Roll-up Sign Bracket
7	Stationary Leg with Leg Cap (Kick-Pin, Flat Spring & Hardware not Included)
8	Smaller, Telescoping Leg with Rubber Caps
9	Rubber Leg Caps (Set of Four)
10	Kick-Pin Replacement Kit (Set of One)
11	Leg Collar (Set of One)
12	Leg Bracket (Set of One)
13	Hardware Kit for Legs (Set of Four)

- Aluminum components – 6061-T6 with .100" wall thickness on tubular structures
- Sign stand footprint – 60" W x 87" D
- Folded dimensions – 36" H x 6 3/8" W x 6 3/8" D
- Sign mounting height – 6' 6"
- Weight – 26 lbs. (without cross-ribs and sign)
- Rubber feet on each leg are riveted on to prevent loss
- Three piece telescoping upright for achieving minimum storage dimensions
- Full 4-year warranty against defects in workmanship, parts and materials

