

Safe-Hit Type 3 Flexible Delineators are round posts with a recessed cap and one 6" (152.4 mm) reflective wrap. They're used with the Surface Mount Pin Lock Base or Driveable Soil Anchor. Safe-Hit Delineators are rated to withstand 12 vehicular impacts at 90 km/h and rebound. They're impact resistant and stay in place even during prolonged exposure to winds and common, light impacts. Customizable options include delineator post height, post colour and reflective wrap colour.

TYPE 3 FLEXIBLE DELINEATOR, SURFACE MOUNT

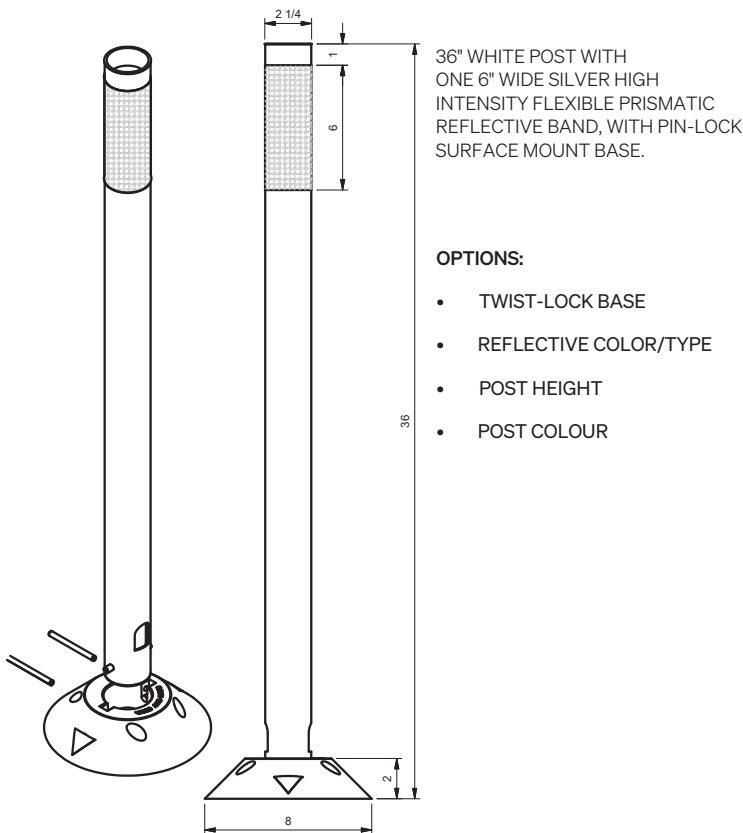

TYPE 3 FLEXIBLE DELINEATOR, GROUND MOUNT

